

GN 607.4 | Indexing plungers

Fixing by means of welding, steel



- 1
- 2
- 3
- 4
- 5
- 6
- 7
- 8
- 9
- 10
- 11
- 12
- 13
- 14
- 15
- 16
- 17
- 18

FLANGED BODY

Black-oxide steel.

PLUNGER

Hardened steel.

KNOB

High-resilience polyamide based (PA) technopolymer, black colour, matte finish.

FEATURES AND APPLICATIONS

GN 607.4 indexing plungers are designed for fixing by means of welding, in particular for applications on square-section steel profiles.

The knurled knob should be assembled to the flanged body after the welding operation to prevent damaging the plastic material.

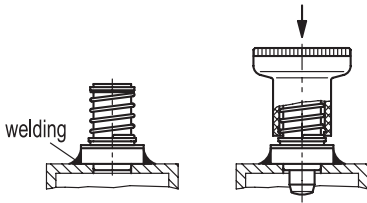

To prevent damaging the plastic material, the handle should be assembled after welding the flanged body by means of a plastic mallet.

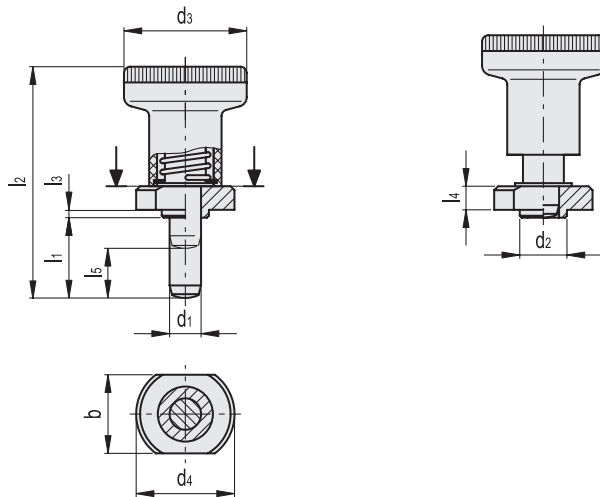

Code	Description	d1		d3	d4	b	l1	l2	l3	l4	l5	Spring preload [N]	Spring max load [N]	Axial holding force [N]	⚖
		Plunger -0.02	Hole +0.30												
GN.34711	GN 607.4-6-6-ST	6	10	25	22	18	6	37	1.5	5.5	6	8.5	22	400	35
GN.34713	GN 607.4-6-14-ST	6	10	25	22	18	14	45	1.5	5.5	6	8.5	22	400	36
GN.34715	GN 607.4-8-8-ST	8	12	31	25	20	8	44	2	6.5	8	15.5	28	500	56
GN.34717	GN 607.4-8-18-ST	8	12	31	25	20	18	54	2	6.5	8	15.5	28	500	60

Indexing and positioning elements